

EXPLODED VIEW & PARTS LISTING

Air Operated Double Diaphragm Pump

Model: DP-50BFT-HD (XDP)

Model #: 854454



To Purchase:

☎ 800-990-7867

✉ sales@yamadapump.com

📍 Find My Rep

More Information:

▶ YouTube: @yamadapump

🌐 yamadapump.com

Data Sheets | CAD Drawings | Manuals Literature | BOM | Performance Curves

Trial Program

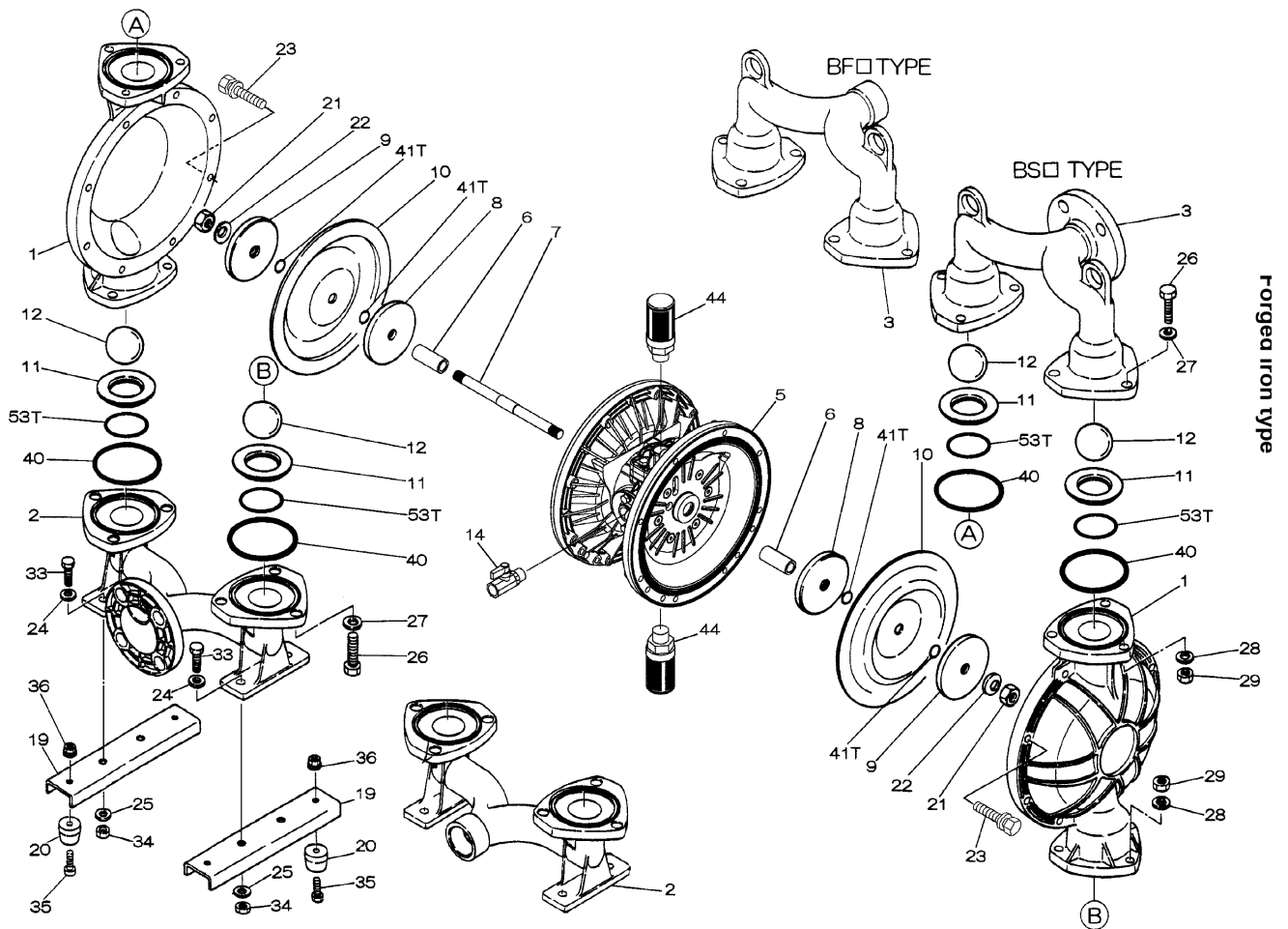

Air Operated Double Diaphragm Pump

804853 Center Body Assembly

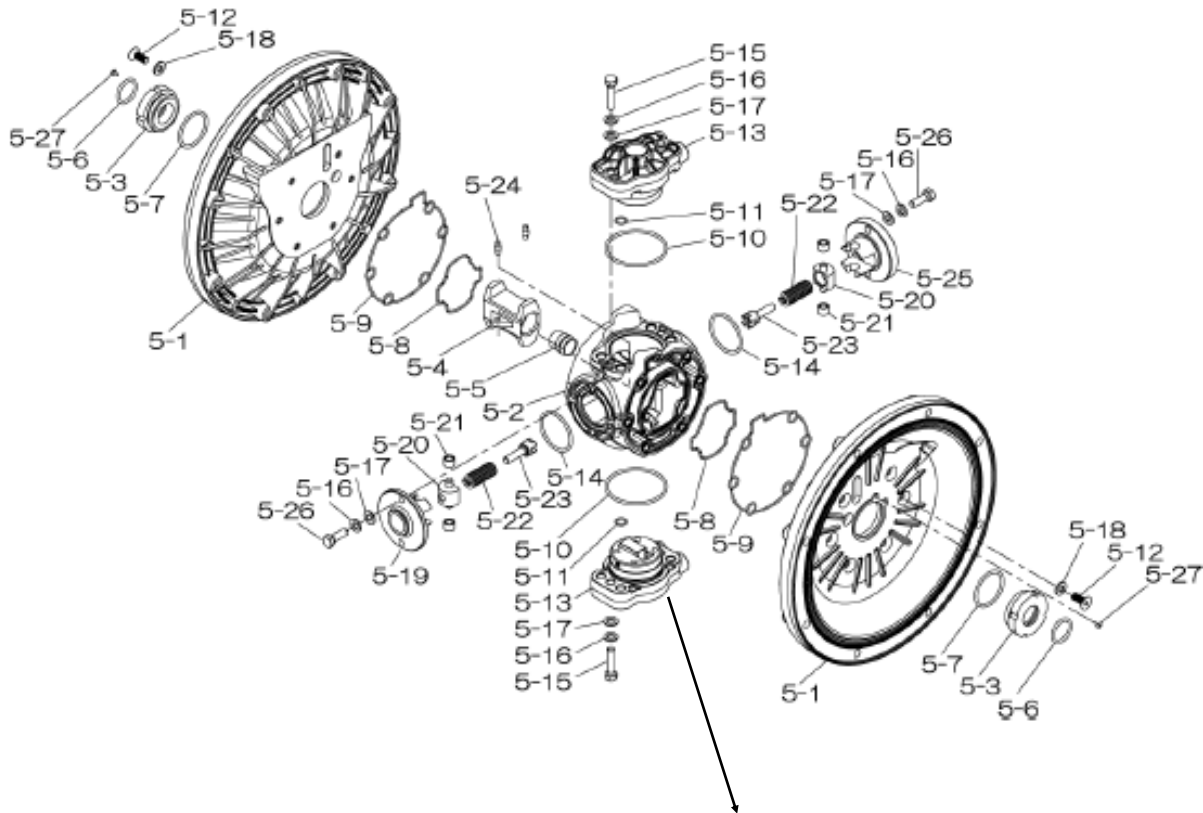

804784 Valve Body Assembly

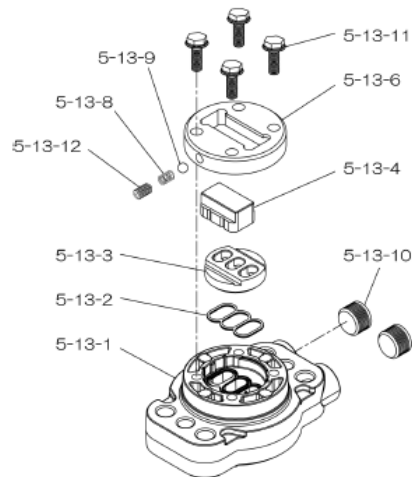

Air Operated Double Diaphragm Pump

REF. NO.	PARTS NO.	DESCRIPTION	QTY.	REORDER
1	713157	OUT CHAMBER	2	
2	713169	IN MANIFOLD	1	
3	713166	OUT MANIFOLD	1	
5	804853	CENTER BODY ASSY	1	
5-1	716247	AIR CHAMBER	2	
5-2	716256	BODY	1	
5-3	773095	THROAT BEARING	2	
5-4	716214	SHUTTLE	1	
5-5	773047	CENTER ROD GUIDE	1	
5-6	640023	O-RING	2	
5-7	640133	O-RING	2	
5-8	773040	GASKET	2	
5-9	773041	GASKET	2	
5-10	640138	O-RING	2	
5-11	640007	O-RING	8	
5-12	683812	FLAT SOCKET	12	
5-13	804784	VALVE BODY ASSY	2	
5-13-1	716244	VALVE BODY	1	
5-13-2	773042	GASKET	2	
5-13-3	716246	SEAT	1	
5-13-4	773425	BLOCK	1	
5-13-6	773426	GUIDE PLATE	1	
5-13-8	706612	SPRING INK	1	
5-13-9	686271	BALL	1	
5-13-10	772934	PLUG	2	
5-13-11	602300	TAPPING BOLT	4	
5-13-12	610025	HEX. SOCKET HEAD SCREW	1	
5-14	640134	O-RING	2	
5-15	611153	BOLT	4	
5-16	631420	SPRING WASHER	8	
5-17	631013	FLAT WASHER	8	
5-18	684987	WASHER	12	
5-19	716249	RETAINER	1	
5-20	713620	SPRING GUIDE	2	
5-21	773067	BUSH	4	
5-22	684537	SPRING	2	
5-23	714446	TRIP ARM	2	
5-24	700231	PIN	2	
5-25	716216	RETAINER	1	
5-26	611149	BOLT	4	
5-27	686337	TAPPING SCREW	2	

REF. NO.	PARTS NO.	DESCRIPTION	QTY.	REORDER
6	716399	CENTER BUSH	2	
7	716404	CENTER ROD	1	
8T	707822	CENTER DISK	2	
9	713390	CENTER DISK	2	
10	770815	DIAPHRAGM	2	
11	711909	VALVE SEAT	4	
12	770693	BALL	4	
14	686974	BALL VALVE	1	
19	711928	BASE	2	
20	771402	FOOT RUBBER	4	
21	706128	NUT	2	
22	682740	WASHER	2	
23	686160	BOLT	16	
24	631014	FLAT WASHER	4	
25	631937	WAVE WASHER	20	
26	611202	BOLT	12	
27	631015	FLAT WASHER	12	
28	631938	WAVE WASHER	12	
29	627014	NUT	12	
33	611175	BOLT	4	
34	627013	NUT	4	
35	611149	BOLT	4	
36	682276	NUT W/FLANGE	4	
40	643069	O-RING	4	
41T	643015	O-RING	4	
44	804697	MUFFLER	2	
53T	643139	O-RING	4	
KIT	K50-MT	LIQUID SIDE KIT		
KIT	K45-AM-DP-HD	AIR MOTOR KIT		

Torque Requirements:

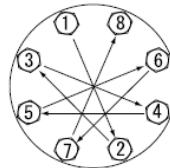

Tightening torque for center rod and out chambers.

- Center Rod 43 ft-lbf {60 N-m}
- Out Chambers 29 ft-lbf {40 N-m}

- Tightening torque for manifold retainer bolts.
BFT-HD 18 ft-lbf {25 N-m}

General Tools:

- Socket wrench - 24mm
- Hexagonal box wrench - 5mm, 6mm
- Open-end wrenches - 19mm, 24mm
- Phillips head screw driver

Special Tools:

- Socket (804129) for a guide to remove the throat bearing (sold separately)

Miscellaneous:

- Assembly Oil - Turbine oil class 1 (equivalent to ISO VG32 grade)
- Nuts - M16 x 1.5
- Thread locker
- Urea grease grade (NLGI) No. 2, Shell Alvania Grease S1

Customer Notes

Model #: _____
 Description: _____
 Serial #: _____
 Date Installed: _____
 Department Location: _____
 Tag/Project: _____